



Operation and Maintenance Instructions

Unit Heaters LH (Translation of the original)



Index	General.....	3
	Symbols.....	3
	Safety instructions.....	4
	Standards and regulations.....	4
	Unit description.....	4
	Installation and operation instructions.....	5
	Prior to the installation.....	6 - 7
	Installation instructions.....	8 - 10
	Electrical connection.....	11
	Switches.....	12 - 14
	Control devices for damper actuators.....	15
	Thermostats.....	16
	Control system WRS.....	17-20
	Actuators.....	21
	Push-button.....	21
	Intermediate terminal box.....	22
	Maintenance.....	23
	Frost protection.....	23
	Hydraulic adaption of unit heaters within a group.....	24
	Rain protection hood and roof lead-in box.....	25- 26
	Notes.....	27

General

The present operation and maintenance instructions are exclusively applicable for Wolf unit heaters LH.

Read these instructions carefully prior to the installation.

These instructions, as a part of the unit, have to be kept accessible.

No warranty claims will be accepted if operation and maintenance instructions are not adhered to.

Symbols

The following symbols are used in these instructions. These important instructions concern personal safety, as well as technical reliability.



"Safety instructions" are instructions with which you must comply exactly, to prevent injury and material losses.



Danger through "live" electrical components.

Never touch electrical components or contacts when the ON/OFF switch is in the ON position.

This creates a risk of electrocution, which may cause injury or death.



"Attention" indicates technical instructions which you must observe, to prevent material losses and unit malfunctions.

In addition to the operation and maintenance instructions there are as well stick-on labels on the unit, which have to be adhered to in the same manner.

Safety instructions



Installation, commissioning, service and operation may only be carried out by qualified personnel.



For electrical installations VDE regulations and local guidelines have to be adhered to.

The unit may only be operated within the capacity range indicated in the technical documents of Messrs. Wolf.

The unit may only be applied for purposes of ventilation. It is only suitable for air. The air must not contain any hazardous, combustible, explosive, aggressive, corrosion developing or any other dangerous substances.

The unit may only be operated in technically perfect condition. Any malfunction or damage which may influence the safety or perfect function of the unit have to be eliminated by a recognized specialist, at once.

Damaged unit components may only be replaced by original Wolf - spare parts.



Only qualified electricians are allowed to perform work on electrical appliances or components, adhering to the electric regulations.



It is not allowed to work in the direct vicinity of a running fan. There is a risk of being hurt by the running fan.

Before undertaking maintenance work, always ensure that the system main isolator / the repair switch(es) are OFF and locked to prevent unintentional reactivation.

Standards, Regulations

The following standards and regulations apply to the LH unit heaters:

- Machine directive 2006/42/EU
- Low voltage directive 2006/95/EU
- EMC directive 2004/108/EU
- DIN EN 12100 Safety of machines; general design principles
- DIN EN 13857 Safety of machines; safety distances
- DIN EN 349 Safety of machines; minimum distances
- DIN EN 953 Safety of machines; guards
- DIN EN 60204-1 Safety of machines; electric equipment

For the installation and maintenance, the following regulations and safety instructions have to be adhered to:

- DIN VDE 0100 Requirements for high voltage installations up to 1000 V
- DIN VDE 0105 Operation of high voltage installations, general restrictions
- DIN VDE 0701-0702 Repair, modification and testing of electrical appliances

General unit description and design

Wolf unit heaters consist of a zinc plated sheet steel casing. The casing is composed of a self-supporting pentapost profile construction, which is welded and zinc plated, and of zinc plated lateral casing panels.

The casing is provided with a LPHW-heating coil which consists either of copper tubes and aluminium fins or galvanized, finned steel tubes.

The air inlet is provided with a unit consisting of an axial fan-motor-protection grille assembly which takes the air in via the air inlet in the rear panel. While passing the heat exchanger on the discharge side the air is heated. The warm airstream may be turned downwards via an adjustable discharge louvre.

Heat exchanger

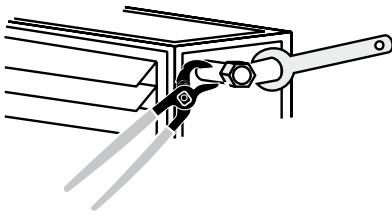

When connecting the heat exchanger counterhold with pipe-wrench.

The flow of the heating system has to be connected on the air discharge side of the heat exchanger.

For steam:

- Steam connection on top
- Condensate return on bottom of discharge side
- Connections on left hand side only, in direction of air flow

Attention : Evacuation of air and fluid has to be provided on site!

Operation limits for LPHW/MPHW:

- Heat exchanger Co./Al., type 1, 2, 3, 4, NP 16, up to 140°C (threaded sleeves)
- Heat exchanger steel-galvanized, NP 10, up to 140°C (threaded sleeves)
- Heat exchanger steel-galvanized, NP 10, up to 180°C (welded flanges)

Operation limits for steam:

- Heat exchanger Co./Al., type D, up to 9 bar saturated steam
- Heat exchanger Co./Al., up to 9 bar saturated steam

Electric heater

To avoid overheating, pay attention to the following minimum air volumes:

LH		25	40	63	100
Luftrichtung horizontal	\dot{V} min [m³/h]	800	1600	2500	4000
Luftrichtung vertikal	\dot{V} min [m³/h]	1000	2200	3200	5000

Attention : Protective measures: In any case it has to be secured that the electric heater is switched off when the air volume is falling below the indicated minimum. Additionally, the electric heater may only be set into operation by one or several magnetic switches whose control circuit leads over the automatic overheating controllers wired in line. Pay attention to the fact that at least one automatic controller has to be mounted on top of the electric heater.



In any case, protect against water

Ceiling-mounted unit

Attention : In ceiling-mounted units there may occur damages by overheating when motor is switched off. For this reason the water inlet temperature has to be limited on:

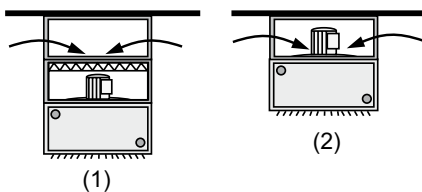

- 115°C when additional sections are mounted (1)
- 140°C without additional selections (2)

- Motor for higher surrounding temp. (on request)
- 140°C when additional sections are mounted (2)
- 180°C without additional sections (2)

When fan stops all control valves have to be closed automatically.

Motors

LH-three-phase motors (except explosion proof motors) may either operate on low speed Y or on high speed Δ . The motor windings are designed accordingly.

Motors for single-phase alternating current may only operate on high or low speed depending on delivery.

LH-single-phase and three-phase motors (except explosion proof motors) are protected with thermal cutouts, which interrupt the control circuit of switch or step switch in case of overheating of the fan motor.

When temperature decreases, the motor switches on automatically.

Attention : The winding protection works only in case of switching the thermal cutouts to the control circuit of a switch or step switch.

Using switches or speed controllers not delivered by Wolf, we can't take any warranty!

Clearances

Clearances for LH ceiling unit or wall unit in metres

LH	LH to LH	LH to wall
25	7 - 9	3 - 4
40	9 - 11	3 - 5
63	11 - 13	4 - 6
100	13 - 15	5 - 7

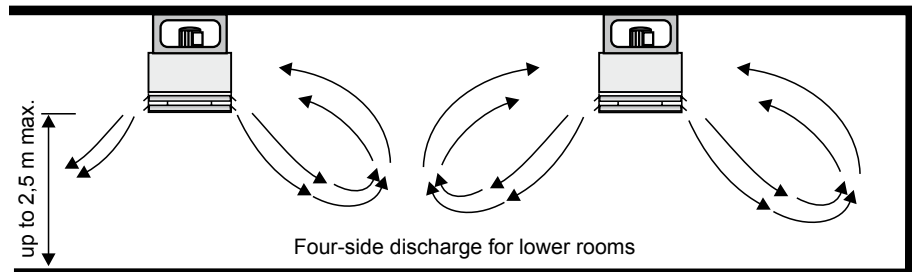
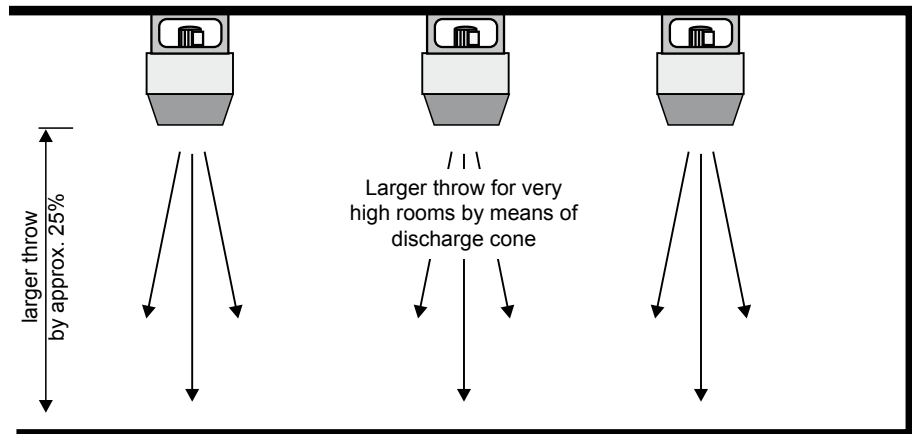
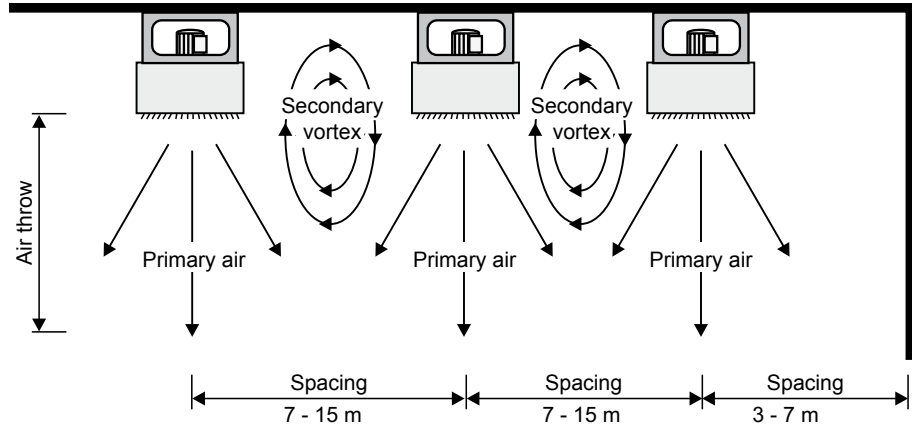

Discharge accessories

referring to a.m. spacing, a Δt air (= t discharge - t room) of approx. 25K and high speed.

LH	25	40	63	100
Spacing: Discharge/Floor up to 2,5 m	4-side-discharge	4-side-discharge	4-side-discharge	4-side-discharge
3-4 m	Wide spread discharge	Wide spread discharge	Wide spread discharge	Wide spread discharge
4-5 m	Cone	Cone	Louvre	Wide spread
5-6 m	Cone	Cone	Cone	Louvre
à partir de 6 m	Cone	Cone	Cone	Cone

If the temperature difference Δt air exceeds 30K the above selection table is no longer applicable, because of the reduced penetration.

Clearances

Clearances for wall-mounted units and clearances for ceiling-mounted units, vanes vertical.

Ceiling-mounted unit, vanes deflected.

LH	25	40	63	100
LH from LH	7 - 9m	9 - 11m	11 - 13m	13 - 15m
LH to wall	3 - 4m	3 - 5m	4 - 6m	5 - 7m
LH from LH	- 12m	- 14m	- 16m	- 18m
LH to wall	4 - 6m	5 - 7m	6 - 8m	7 - 9m

Air throw: wall-mounted unit

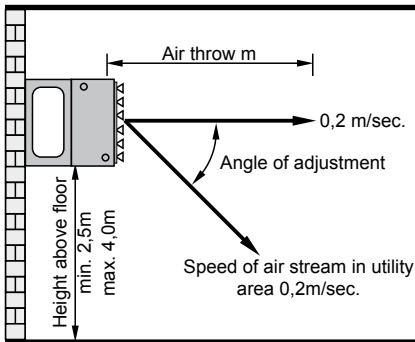

LH	25				40				63				100			
Type	1	2	3	4	1	2	3	4	1	2	3	4	1	2	3	4
Air throw [m]*																
high speed	19	18	16	15	27	26	23	21	29	27	25	23	36	35	34	32
low speed	16	15	13	12	20	19	16	14	22	20	18	17	30	28	26	25

* Figures represent air throws on defined operating conditions. (mixing temperature 10 K above room temperature)

Height above floor, ceiling-mounted unit

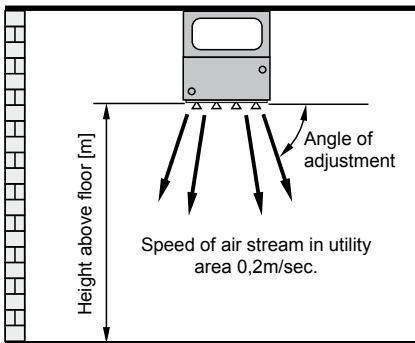

LH	25				40				63				100			
Type	1	2	3	4	1	2	3	4	1	2	3	4	1	2	3	4
Height above floor [m]*	5	4,5	4	3,5	6	5,5	5	4,5	7	6,5	6	5,5	8	7,5	7	6,5

*The optimum vane angle depends on the height above floor.

Higher above floor heights on request.

Height wall-mounted unit with adaption cone and induction louvre

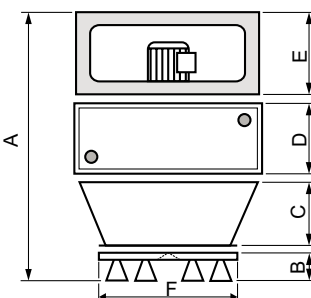

	A	B	C	D	E	F
LH 63	1040	120	270	300	350	460
LH 100	1130	120	320	340	350	590

LH	63		100	
Type	1	2	1	2
Max. height (m)	12	11	11	10

Higher above floor heights on request.

Suspension angles

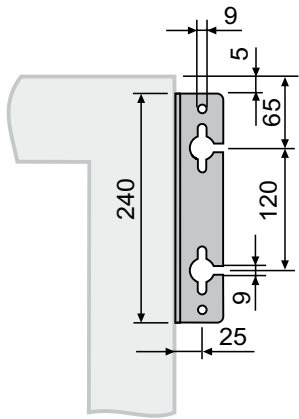

Attach the suspension angles to LH-unit.

For mounting on the ceiling with horizontal air outlet, first fix screws \varnothing 8 mm (on site) to the ceiling. Hang up LH-unit at key holes and tighten screws.

For sloping the LH-unit from the ceiling, insert threaded shaft (8 mm) from side through slot of key holes and tighten by nut, counter-nut and 2 washers.

Depending on the construction of the ceiling, use appropriate screws and dowel pins, if necessary.

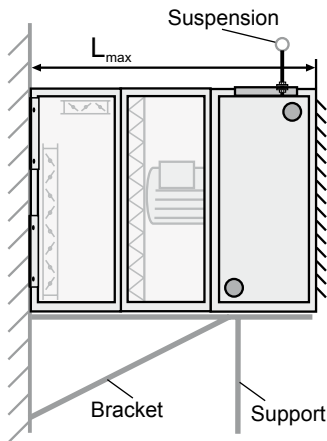
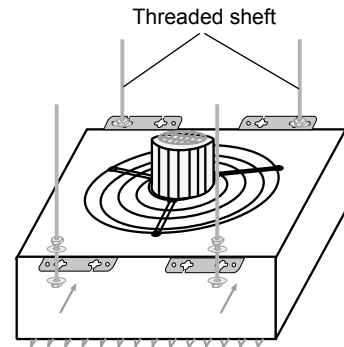
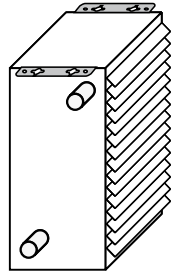

Fix screws \varnothing 8 mm to wall.

Hang up LH-unit and suction accessory by means of key-holes and tighten screws.

For wall-mounted units exceeding a max. length L_{max} . provide an additional support or suspension on-site.

LH 100 with steel-galvanized heat exchangers type 2 and 3 require this additional support or suspension already at a unit-length of $L = L_{max}$.

LH	25	40	63	100
L_{max} [mm]	1100	1100	1100	1220

Mounting brackets

Fit mounting brackets to LH-unit by means of enclosed screws.

Attach screws to wall of ceiling according to measure "c".

Hang up LH-unit by means of key holes of mounting brackets and tighten screws.

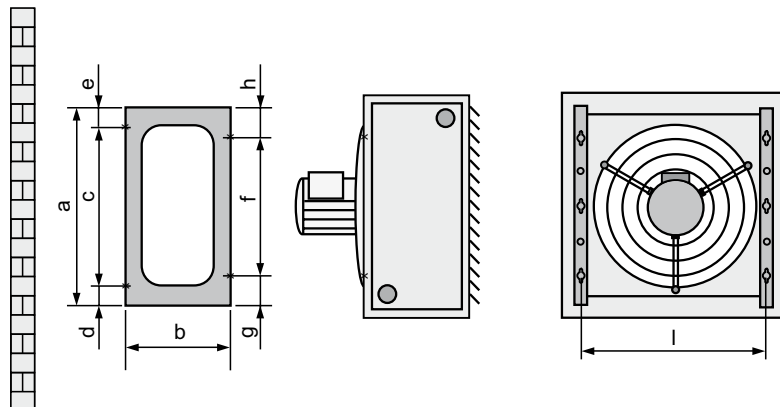

LH	a	b	c	d	e	f	g	h	i
25	480	250	380	70	30	170	155	155	434
40	480	250	2 x 170	90	50	2 x 170	70	70	564
63	784	350	170+340+170	72	32	3 x 170	137	137	734
100	784	350	170+340+170	72	32	3 x 170	137	137	894

Dimensions en [mm]



Prior to the application of fastening sets the static conditions of the concrete or steel bars have to be checked and taken into account. Assembly exclusively with basic units at a total depth of 300 mm.

Fastening kit for concrete bar vertical

- Fasten fixing rail with dowels and screws, provided on site, to the concrete bar.
- Fit fastening brackets to the unit with enclosed screws.
- Fit suspending rails to the fastening brackets with enclosed screws, washers and nuts.
- Hang total assembly (unit fastening brackets and suspending rails) into fixing rail.

To prevent the unit from dropping before fitting the pipework, the inferior suspending rail may be secured additionally by fitting it to the concrete bar with screws and dowels.

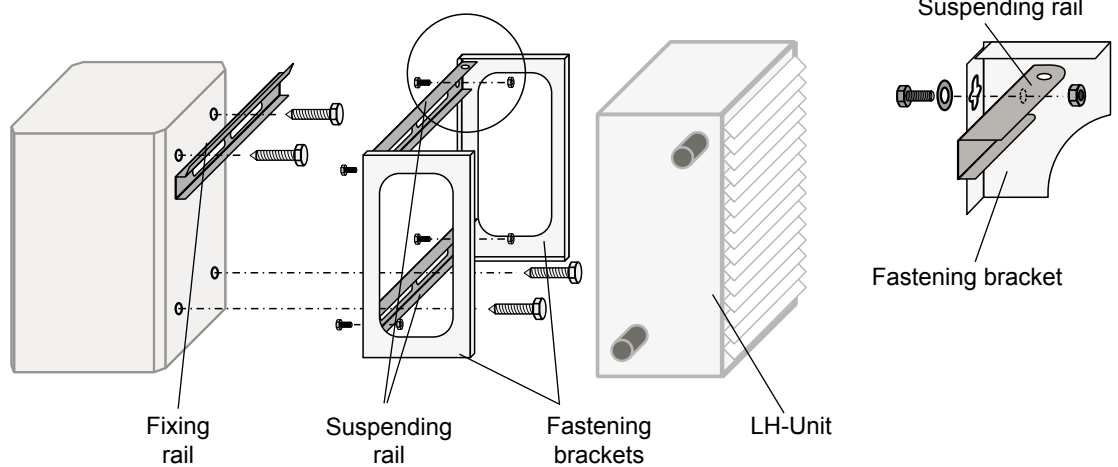

Fastening kit for steel bar vertical

Suitable for all types of steel bars at a flange width "b" of min. 100 mm up to max. 300 mm, and a flange thickness "t" of min. 6 mm up to max. 21 mm.

- Fit fixing rail to steel bar with enclosed clamping jaws.
- Fit fastening brackets to the unit with enclosed screws.
- Fit suspending rails to the fastening brackets with enclosed screws, washers and nuts.
- Hang total assembly (unit, fastening brackets and suspending rails) into fixing rail.
- Fit inferior suspending rail to steel bar with clamping jaws.

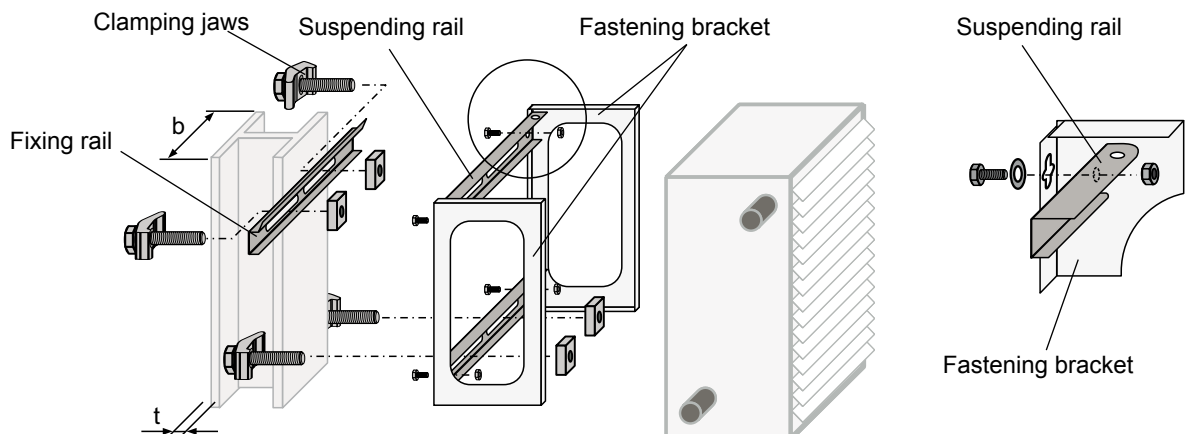

Fastening kit for steel bar inclined with inclination equalization

Suitable for all types of steel bars at a flange width "b" of min. 100 mm up to max. 300 mm and a flange thickness "t" of min. 6 mm up to max. 21 mm.

- Fit fastening brackets to the unit with enclosed screws.
- Fit angle steel profiles of inclination equalization with their short end to the suspending rails, by using the enclosed screws and nuts.
- Connect angle steel profiles at their long ends and keep them movable.
- Fit suspending rails to the steel bar with enclosed clamping jaws.
- Fit unit to inclination equalization assembly via its fastening brackets by means of threaded rods M8 (on site).

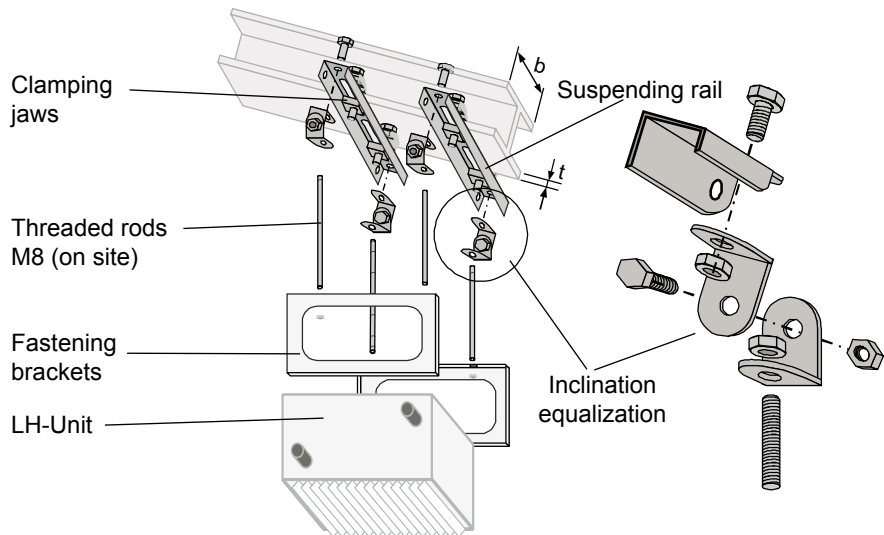

Fastening kit for steel bar horizontal and inclined without inclination equalization

Suitable for all types of steel bars at a flange width "b" of min. 100 mm up to max. 300 mm and a flange thickness "t" of min. 6 mm up to max. 21 mm.

- Fit fastening brackets to the unit with enclosed screws.
- Fig. 1 and 2:
 - Fit suspending rails to the fastening brackets with enclosed screws, washers and nuts.
 - Fit suspending rails to the steel bar with enclosed clamping jaws, as shown in fig. 1 and 2.
- Fig. 3:
 - Fit suspending rails to the steel bar with enclosed clamping jaws.
 - Fit unit to suspending rails via its fastening brackets by means of threaded rods M8 * (on site).

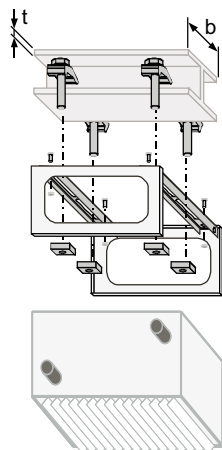

Fig. 1

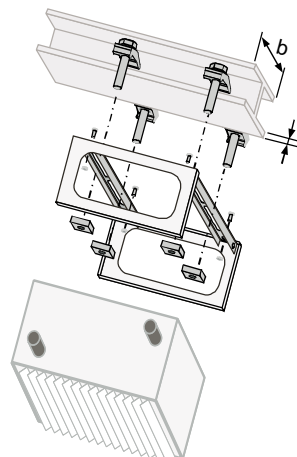

Fig. 2

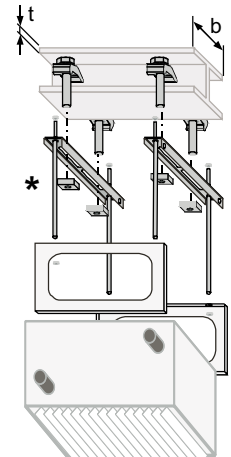
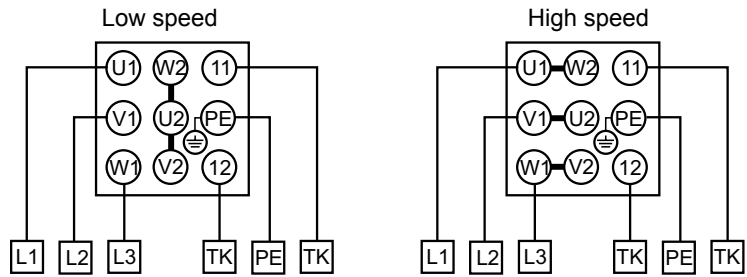

Fig. 3

Three-phase-motors



Operation of several LH-units with one switch or control device

LH-units of different sizes and capacity can be operated with one switch up to the max. permissible capacity or max. permissible current of the switch.

When operating several LH-units, the motor terminals have to be switched parallel, the thermal cutouts and anti-frost thermostats in line! Terminal clamp 5 on site.

LH-unit with thermal cutouts and anti-frost thermostat

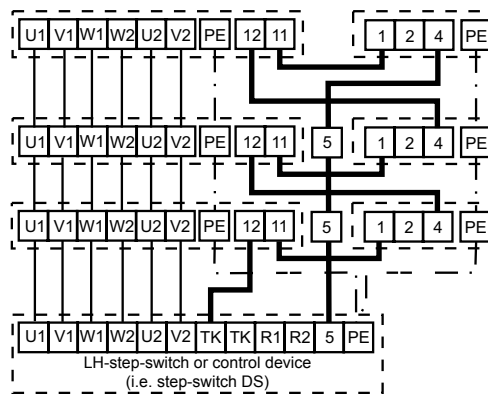

LH-unit with thermal cutouts

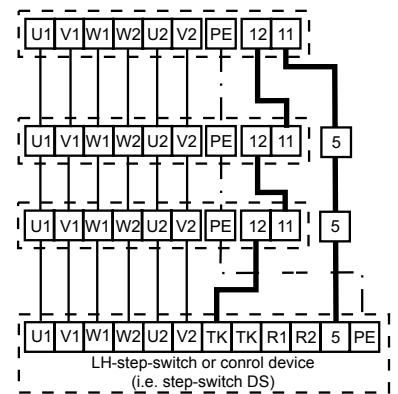

Single-phase-AC-motors 230 V / 50 Hz

Single-phase-AC-motors are delivered only in high-speed-wiring.

Wire thermal cutouts in line with motor winding.

Speed control with 5-step-switch type E5-...

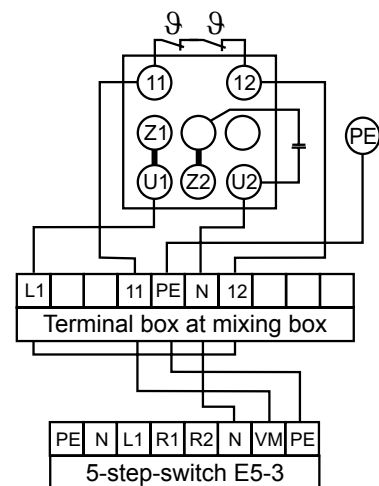
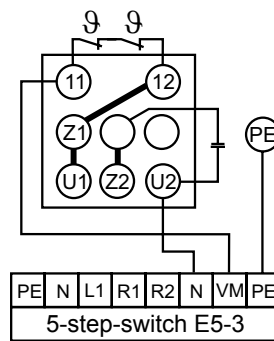

Single-step switch D1

for single-speed operation of one or several unit heaters.

Operation voltage	400 V
Control voltage	230 V
Max. capacity	3 kW
Weight	0,9 kg
Prot. class	IP 54
Part no.	79 40 001

Automatic start-up when winding temperature drops (motor).

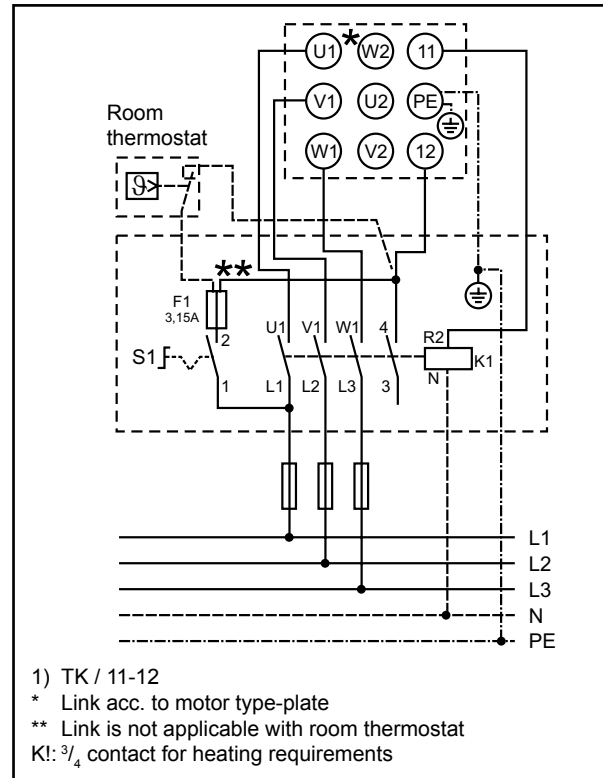

Two-step switch DS

for two-speed operation of one or several unit heaters.

Operation voltage	400 V
Control voltage	230 V
Max. capacity	4 kW
Weight	0,9 kg
Prot. class	IP 54
Part no.	79 25 110

Automatic start-up when winding temperature drops (motor).

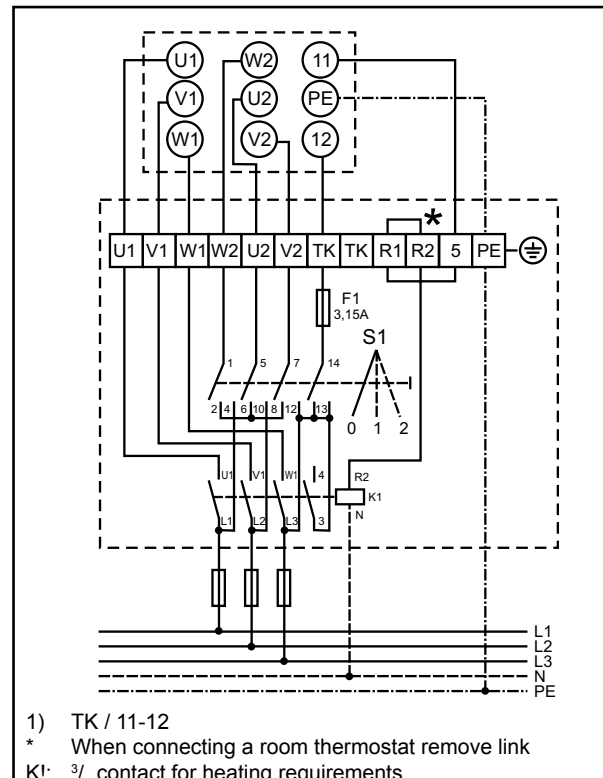

Attention :

Without switches for complete protection we do not give motor warranty!

When the winding temperature is being exceeded without a complete motor protection switch, the motor can get badly damaged.

Complete motor protection switches for 3 x 230 V available on request.

Five-step switch D 5-...

for five-speed operation of one or several unit heaters with complete motor protection with reclosure preventing device.



Type	D5-1	D5-3	D5-7	D5-12	D5-19
Operation voltage	V 400	400	400	400	400
Control voltage	V 230	230	230	230	230
Max. current	A 1	2	4	7	12
Weight	kg 4,5	7,0	9,0	19,0	27,0
Prot. class	IP 40	20	20	20	20
Width	A 150	230	230	230	310
Height	B 200	310	310	310	385
Length	C 175	185	185	185	225
Part number	2740015	2740010	2740013	2740014	2740017

Locking switch-off at winding overtemperature (motor).
 Reclosing: switch position 0, then select required stage.
 Contact for heating requirements.

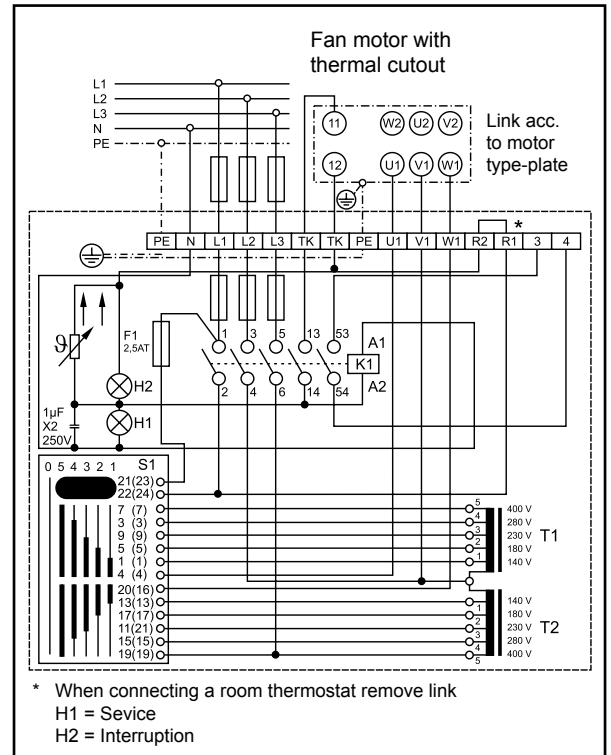

Five-step switch E 5-3

for five-speed operation of one or several unit heaters with single-phase-AC-motors with complete motor protection.

Operation voltage	230 V
Max. current	3 A
Weight	4,0 kg
Prot. class	IP 40
Part no.	27 40 006



Automatic start-up when winding temperature drops (motor).

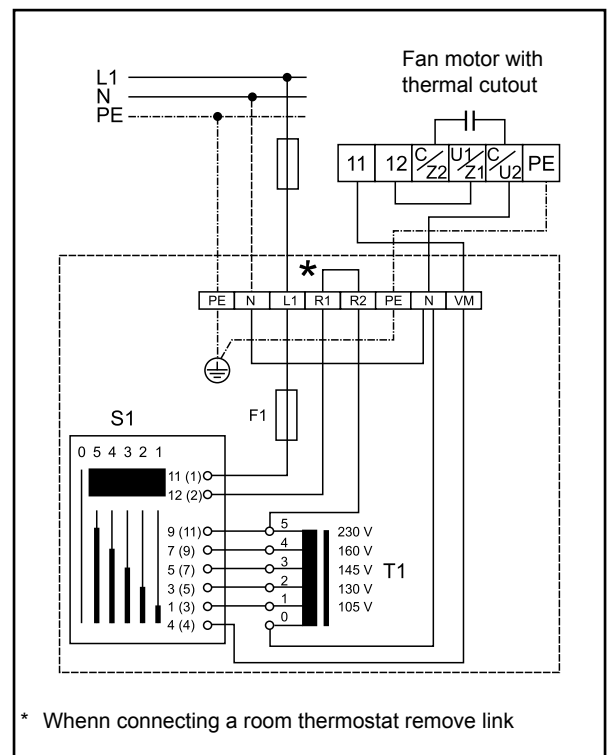

Attention :

Without switches for complete protection we do not give motor warranty!
When the winding temperature is being exceeded without a complete motor protection switch, the motor can get badly damaged.

Complete motor protection switches for 3 x 230 V available on request.

3-stage switch E3-7T with reclosing lock-out

for 3-speed operation of one or more unit heaters with single-phase A.C. motors and complete motor protection.

Operation voltage	230 V
Max. capacity	7 A
Weight	4,5 kg
Prot. class	IP 40
Part no.	27 01 064



Locking switch-off at winding overtemperature (motor).
 Reclosing: switch position 0, then select required stage.
 Contact for heating requirements.

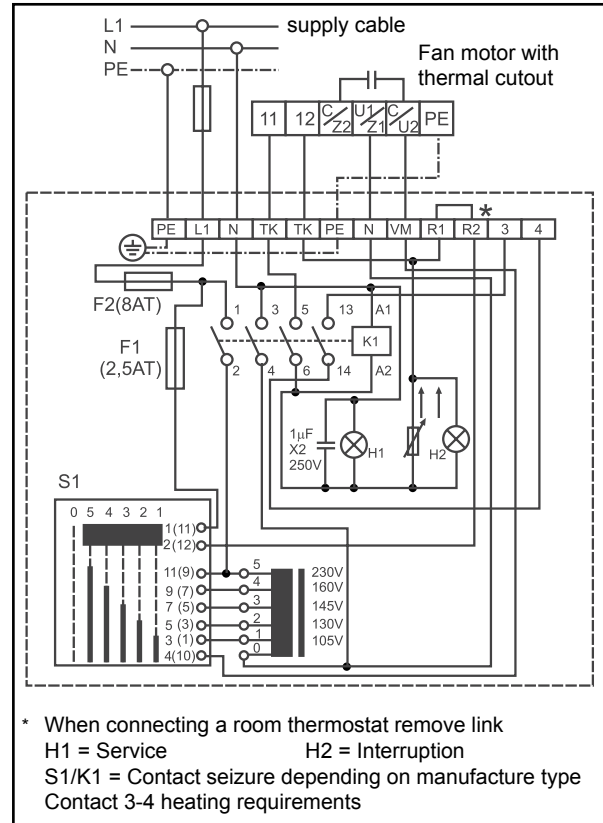

3-stage switch D 3-4 with reclosing lock-out

for 3-speed operation of one or more unit heaters with complete motor protection

Operation voltage	400 V
Control voltage	230 V
Max. capacity	4 A
Weight	8,0 kg
Prot. class	IP 20
Part no.	27 01 065

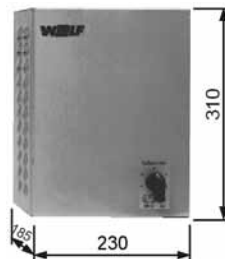

Locking switch-off at winding overtemperature (motor).
 Reclosing: switch position 0, then select required stage.
 Contact for heating requirements.

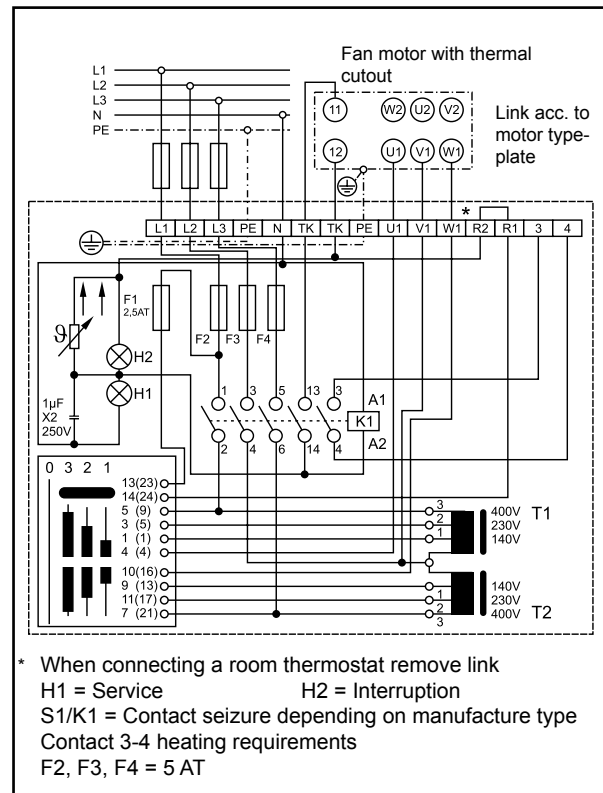

Automatic relay A1

Auxiliary relay for the automatic operation of the fresh air damper with an actuator 230 V "OPEN-SHUT".

The automatic relay A1 switches the actuator to position "SHUT", if the LH-unit is switched off or if the anti-frost thermostat is activated. Switching on the LH-unit, the actuator switches to position "OPEN".



Control voltage	230 V
Max. capacity	3 kW
Weight	0,5 kg
Prot. class	IP 54
Part no.	79 65 020

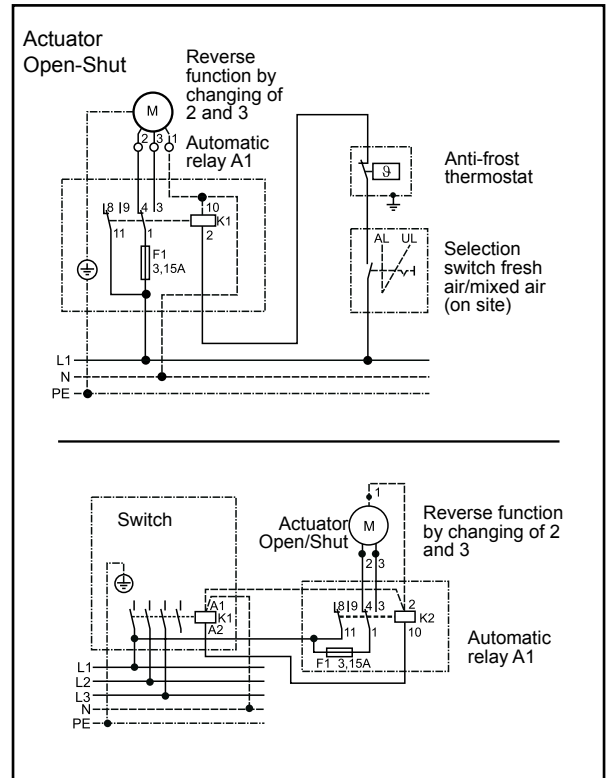

Automatic relay A1S

Auxiliary relay with integrated position transmitter for the automatic operation of the mixed air damper by means of a stepless actuator 230 V.

The automatic relay A1S switches the actuator to the position set on the position transmitter, if the LH-unit is switched off or if the anti-frost thermostat is activated.

Switching on the LH-unit, the actuator switches to the position set at the position transmitter.

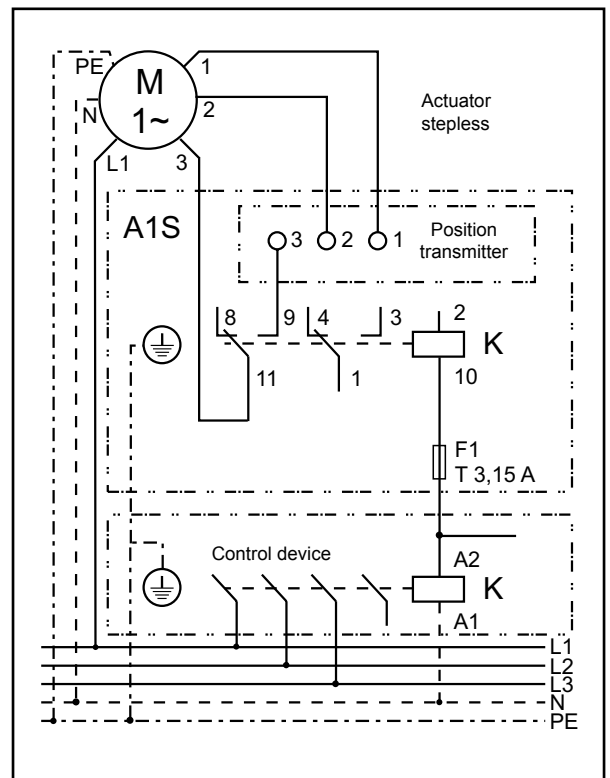

Control voltage	230 V
Max. capacity	3 kW
Weight	0,5 kg
Prot. class	IP 54
Part no.	79 65 012

Room thermostat

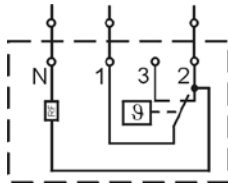

Max. current at 230 V / 50 Hz
 Heating: 10(5) A; Venting: 5(2) A
 Thermal feed-back
 Temperature range 5 - 30 °C
 Differential ± 0,5 K
 Protection class IP 30
 Part no. 27 34 000

Room thermostat with summer-winter-switch

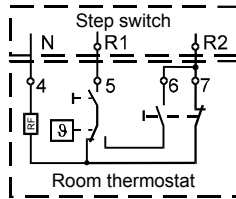

Max. current at 230 V / 50 Hz
 Heating: 10(4) A; Venting: 5(2) A
 Thermal feed-back
 Temperature range 5 - 30 °C
 Differential ± 0,5 K
 Protection class IP 30
 Part no. 27 34 700

Room thermostat Heavy-duty-design

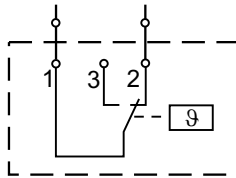

Max. current at 230 V / 50 Hz
 Heating: 16(4) A; Venting: 8(4) A
 Temperature range 0 - 40 °C
 Differential ± 0,75 K
 Protection class IP 54
 Part no. 27 35 300

Room thermostat clock with weekly program

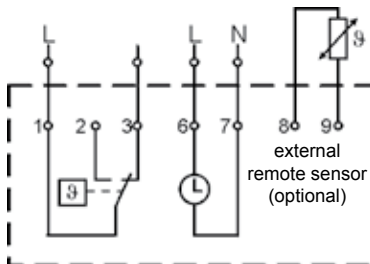

Max. current 10(4) A at 230 V / 50 Hz
 Temperature range 5 - 40 °C
 Differential adjustable 2 - 10 K
 Differential ± 0,1 up to 3 K
 Storage locations 16
 Function reserve 15 minutes
 Shortest switching interval 10 minutes
 Protection class IP 20
 Part no. 27 44 079

Remote sensor for room thermostat clock

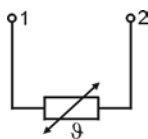

Plastic housing 52 x 50 x 35 mm
 Screw connection M16
 Protection class IP 54
 Part no. 27 35 410

Anti-frost thermostat

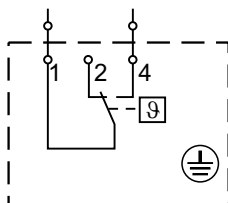

Max. current 10 A at 230 V / 50 Hz
 Range 4,5 °C bis 22 °C
 Differential 2,5 K
 Prot. class IP 43
 Wiring of anti-frost thermostat in line with thermal cutouts!

LH	25	40	63	100
Part no.	27 30 050			27 30 150

BML ventilation programming module

- room-dependent temperature control
- control by rotary selector with key function
- 4 function keys for frequently used functions (info, temperature, speed adjustment, fresh air proportion)
- installation either inside the ventilation control unit or, as remote control, in a wall mounting base
- only one BML ventilation programming module required to control up to 7 zones
- demand-optimised boiler water temperature demand via eBUS
- eBus interface

Wall mounting base

- wall mounting base for use with the BML ventilation programming module as remote control.

LM1 Ventilation control unit (incl. room temperature sensor)

- ventilation module to control air heaters with a two-stage motor
- easy controller configuration by selecting one of the preset system versions
- demand-optimised room temperature control via air heater speed
- control of the heating circuit pump
- control of one heat source
- demand-optimised boiler water temperature demand via eBUS
- eBus interface with automatic energy management

LM2 ventilation control unit

- ventilation module LM2 to control the room temperature via speed or mixing valve
- 2-stage motor control in conjunction with ventilation module LM1, or variable motor control in conjunction with EC motor or external inverter (0-10 V)
- easy controller configuration by selecting one of the preset system versions
- control of one heat source
- demand-optimised boiler water temperature demand via eBus
- eBus interface with automatic energy management
- control of mixed air damper
- induction louvre control

Outside or room temperature sensor**Radio clock**

- for synchronising the clock inside the control unit with the DC77 transmitter

Radio clock with outside temperature sensor

- for synchronising the clock inside the control unit with the DC77 transmitter, and capturing the outside temperature

Supply air sensor and sensor retainer

Ventilation control unit LM1 with BML

Description:

This configuration is used for heating buildings in conjunction with air heaters. The room temperature is captured by a sensor and the fan, the heating circuit pump and the heat source are switched on or off depending on demand.

If the temperature deviation (set room temperature to actual room temperature) is low, the fan is operated in stage 1. If the temperature deviation is greater, it is switched to stage 2.

Example:

Unit heater, heating with room temperature control

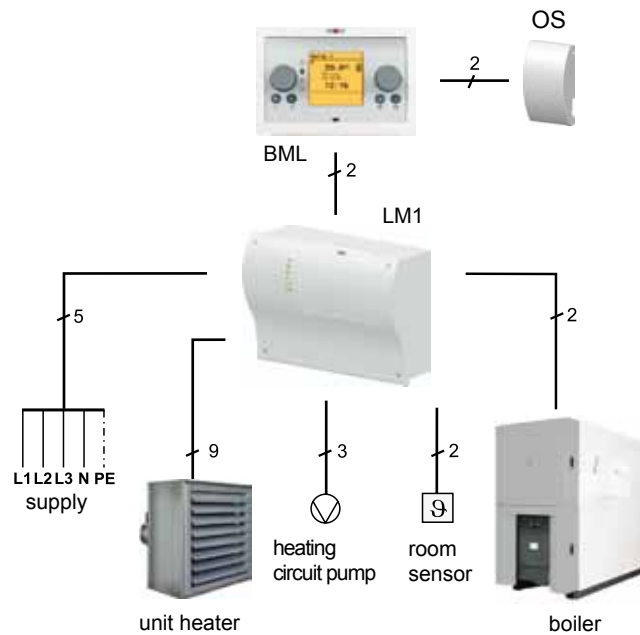

Installation diagram:

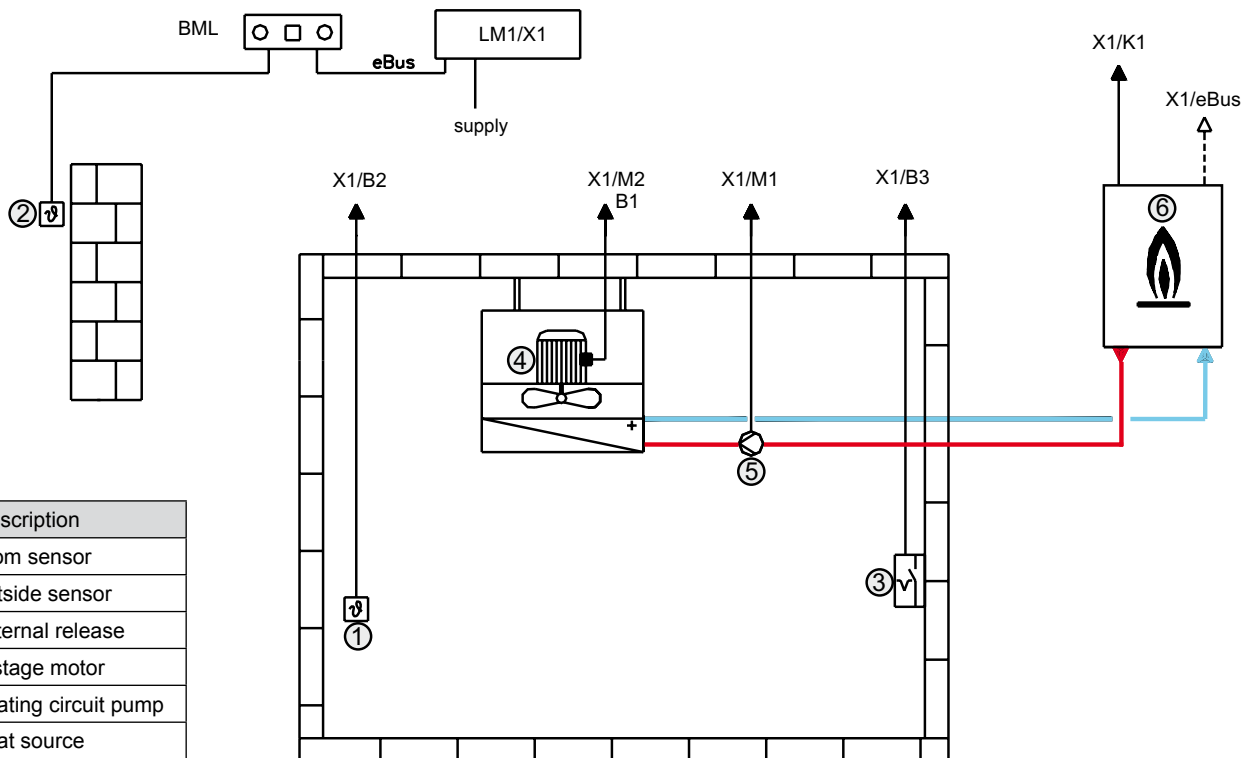

No.	Description
1	room sensor
2	outside sensor
3	external release
4	2-stage motor
5	heating circuit pump
6	heat source

Ventilation control units LM1 and LM2 with BML

Description:

This configuration is used for heating buildings in conjunction with air heaters. The room temperature is captured by a sensor and the fans, the heating circuit pump, the heating circuit mixing valve and the heat source are switched on or off depending on demand.

Example:

Unit heater, heating with room temperature control, mixing valve control, motor control, 2-stage

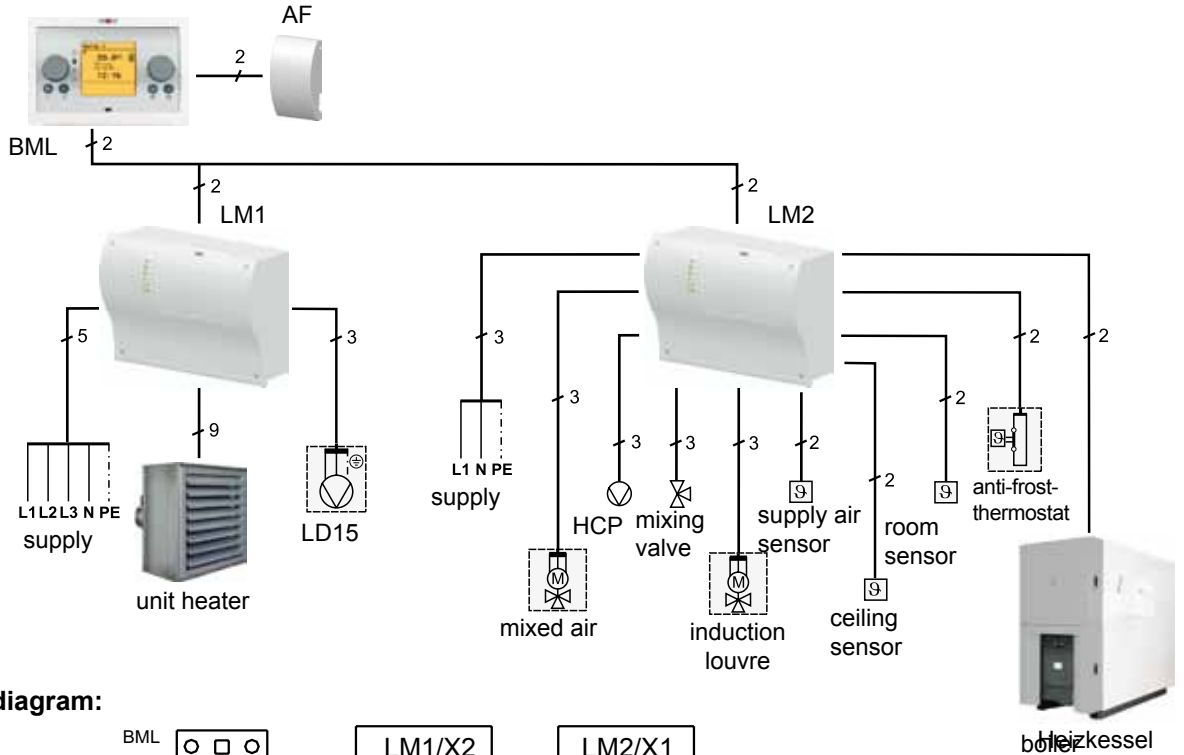

Installation diagram:

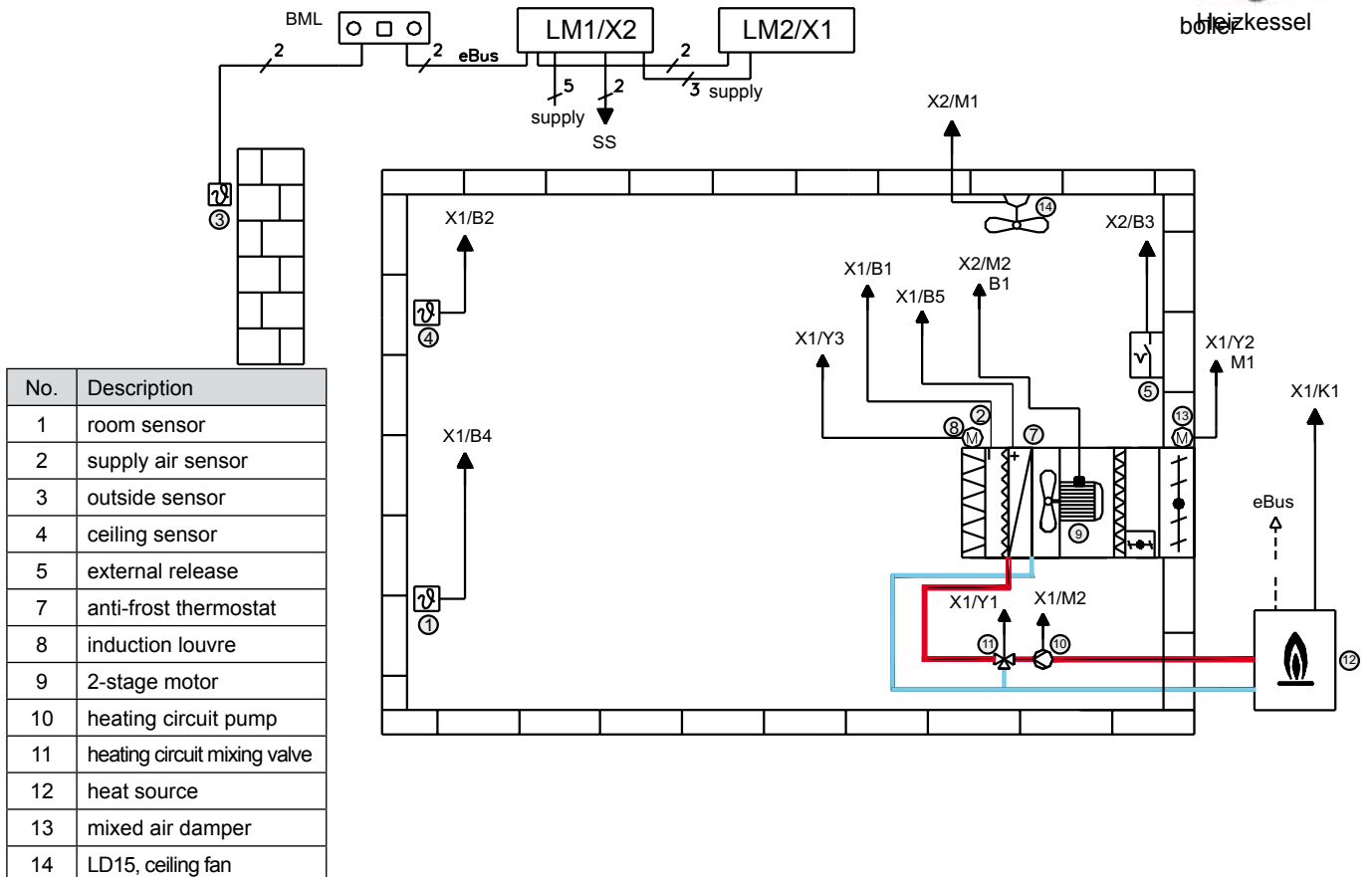

No.	Description
1	room sensor
2	supply air sensor
3	outside sensor
4	ceiling sensor
5	external release
7	anti-frost thermostat
8	induction louvre
9	2-stage motor
10	heating circuit pump
11	heating circuit mixing valve
12	heat source
13	mixed air damper
14	LD15, ceiling fan

LM2 Ventilation control unit with BML

Description:

This configuration is used for heating buildings in conjunction with air heaters. The room temperature is captured by a sensor, and the fans, the heating circuit pump, the heating circuit mixing valve and the heat source are switched on or off depending on demand. The extract air fan is activated depending on the fresh air proportion.

Example:

Unit heater, heating with room temperature control, mixing control, motor control with electronic 5-stage speed regulator

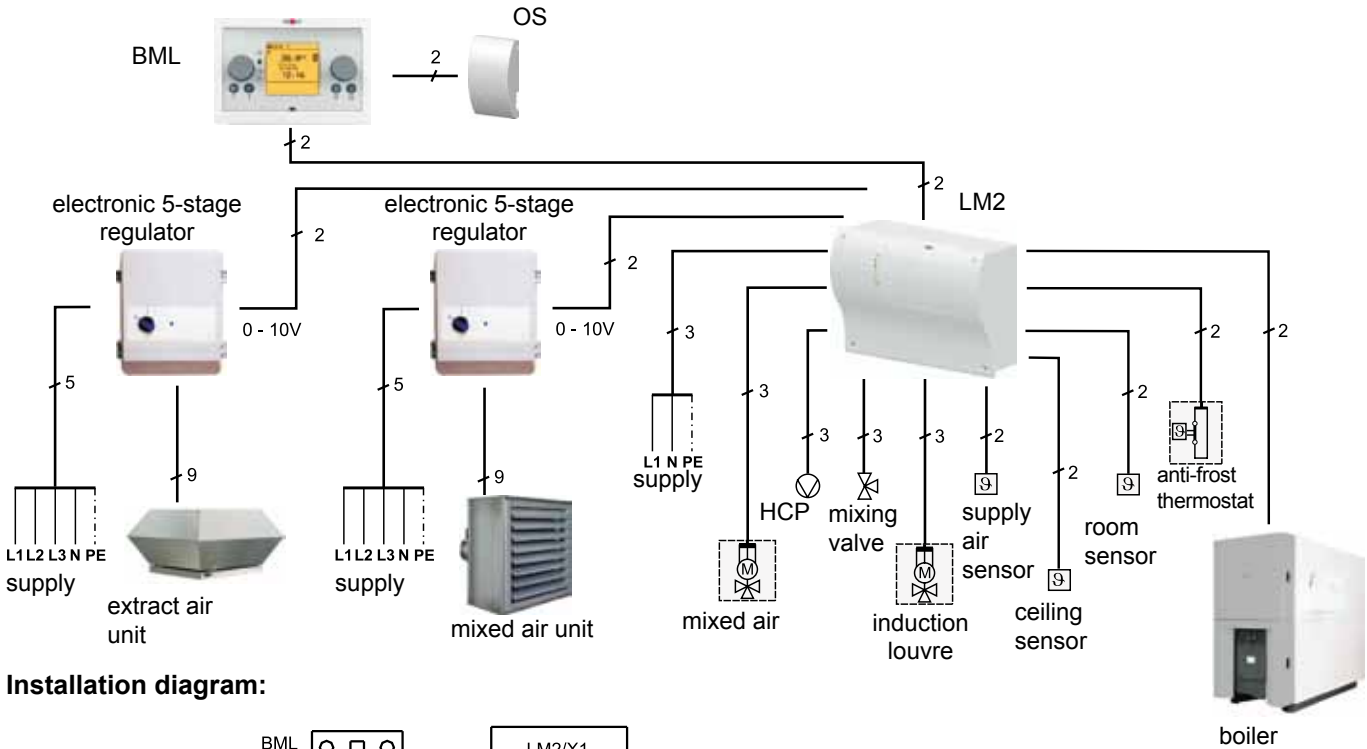

Installation diagram:

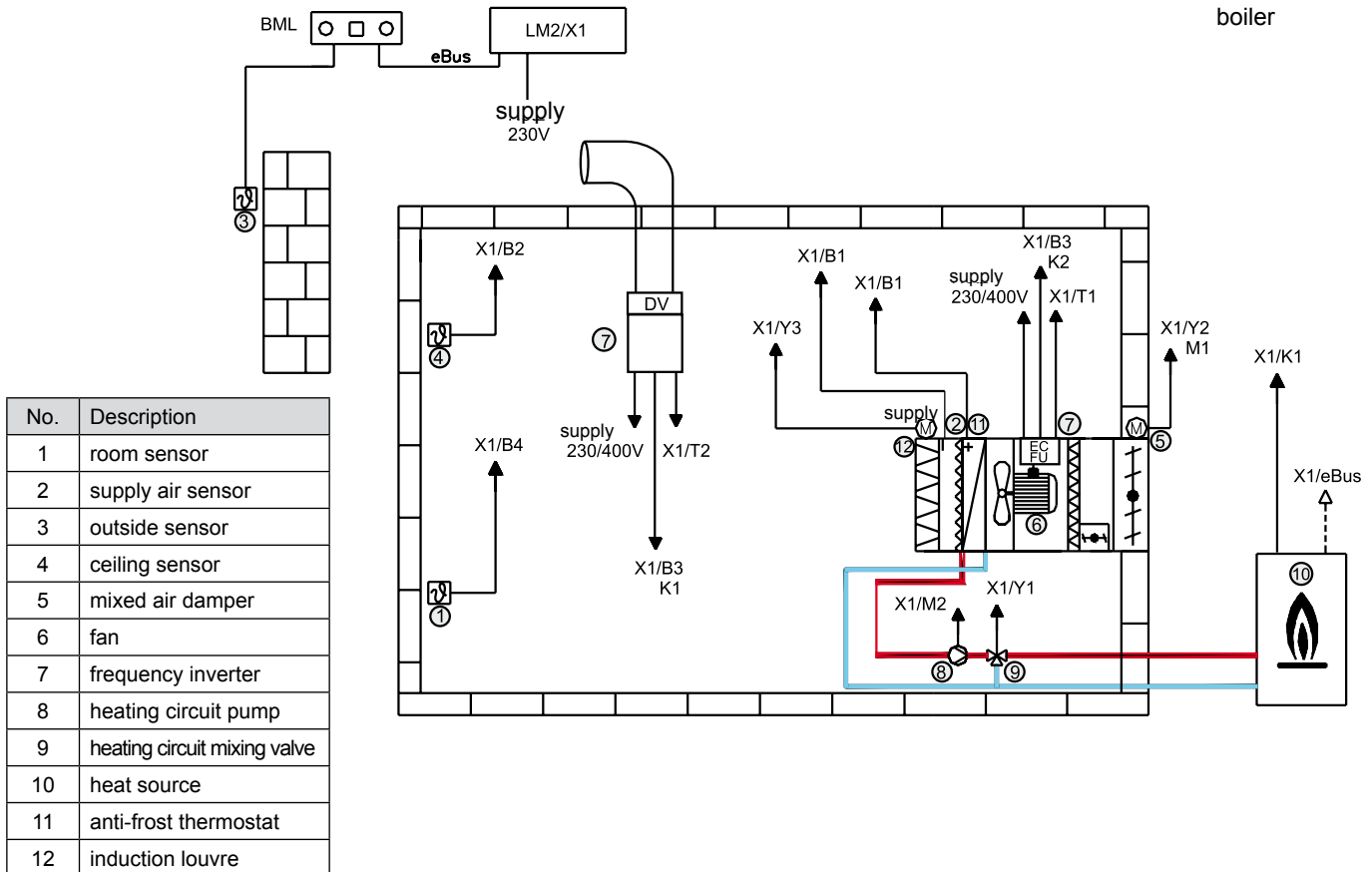

Actuator OPEN-SHUT 230 V / 50 Hz

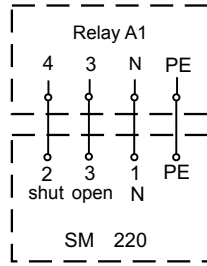

Actuator for automatic opening and closing of the fresh air damper.
Controlling only by automatic relay A1.

Power consumption 11 VA
Rotation direction reversible
Torque drive 15 Nm
Running time 90 - 150 sec.
Protection class IP 42
Part no. 22 69 523

Stepless actuator 230 V / 50 Hz



Actuator for automatic operation of damper, induction louvre and mixing valve.
Controlling only by automatic relay A1 and position transmitter.

Power consumption 5 VA
Rotation direction reversible
Torque drive 15 Nm
Running time 100 - 200 sec.
Protection class IP 42
Part no. 22 69 522

Push-button for 230V/50Hz actuator of induction louvre

for surface or concealed installation;
for progressive control of the induction louvre to optimize the air throw

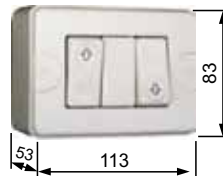

Control voltage	230 V
Max. capacity	10 A
Prot. class	IP 20
Part no.	27 01 063

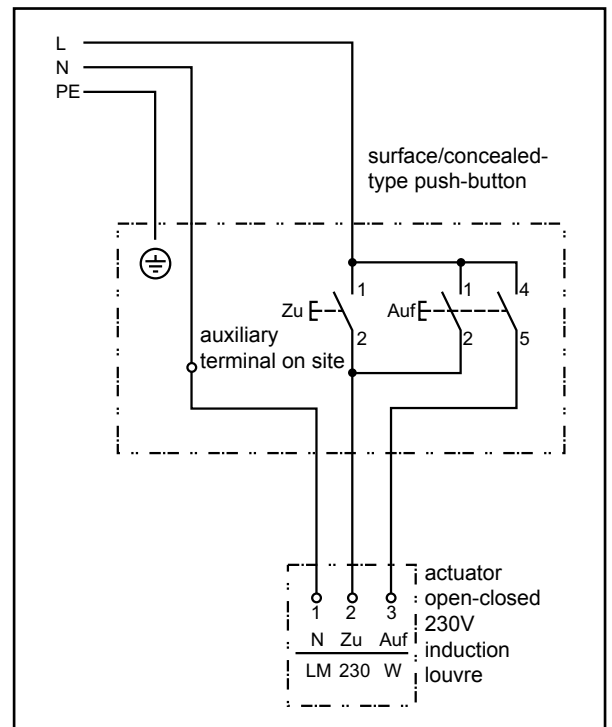

Intermediate terminal box

Intermediate terminal box for a parallel operation of several LH unit heaters.

It is possible to wire one control device and three LH unit heaters or one control device, two LH unit heaters and an additional intermediate terminal box.

LH unit heaters of different sizes and performances of up to the max. possible performance or rather the max. possible current of the switch or control device can be wired.

Wiring according to the attached wiring diagrams.

Connection of 3 LH unit heaters with an intermediate terminal box

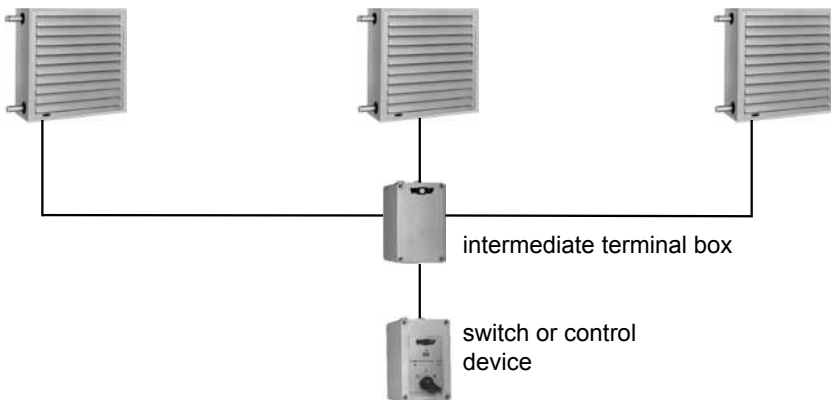

Operation of 7 LH-units with intermediate terminal box

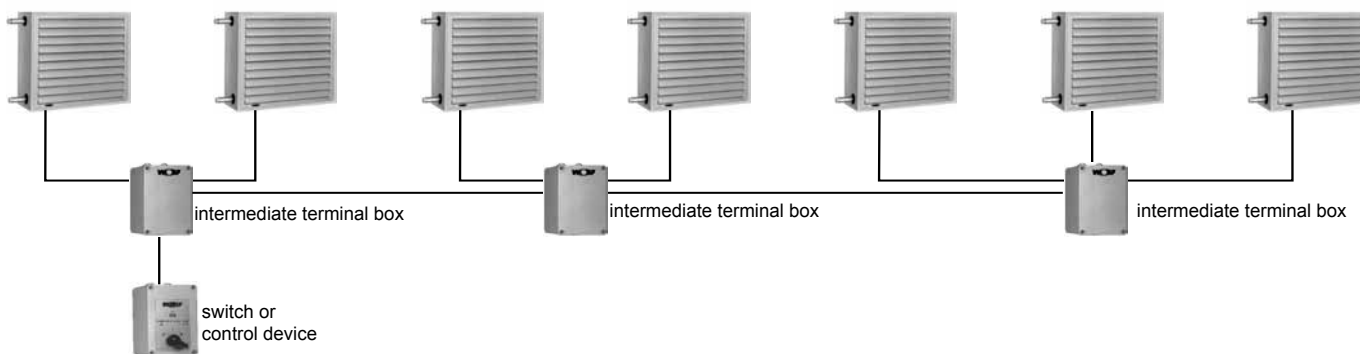

Maintenance**Attention: Do not clean electric heaters with water!**

For cleaning the heat exchanger from dust and dirt use vacuum cleaner or compressed air. For higher dirt accumulation use additionally commercial washing agents and luke warm water or compressed steam (not over 5 bar).

Pull out the filter element on the access side to clean or to renew it.

The filter element can be cleaned with the help of compressed air, batting or vacuum cleaner.

All the remaining parts as motor, fan-impeller, mixing-box, adjustable fins and actuator are maintenance-free.

Prior to finishing maintenance, check safe fastening of the LH-unit.

Frost protection measures

When unit is switched off: Drain all water-filled sections, blow out remaining water with compressed air!

Steam heating coils being directly operated with fresh air have to be provided with steam on total height.

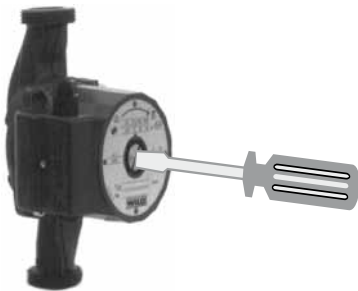
Pump

Before operation and after a longer rest period the pump has to be vented. For this purpose, the LH-unit has to be switched off. To proceed accordingly, remove plug acc. to sketch. When water is evacuated the plug is closed tightly again.

The direction of rotation of the pump is marked with arrows on the type-plate.

Pumps operating with AC always turn into the correct direction of rotation.

Pumps operating with three-phase current have to be checked by removing the plug (threaded to the right) and by controlling the rotation of the shaft.

General instructions

The hydraulic adjustment of unit heaters is a precondition for an economic and optimized control within a group. The hydraulic adjustment aims at a correct flow rate through all unit heaters.

Example 1:

Individual adjustment via control valves (in addition to the connection fittings).

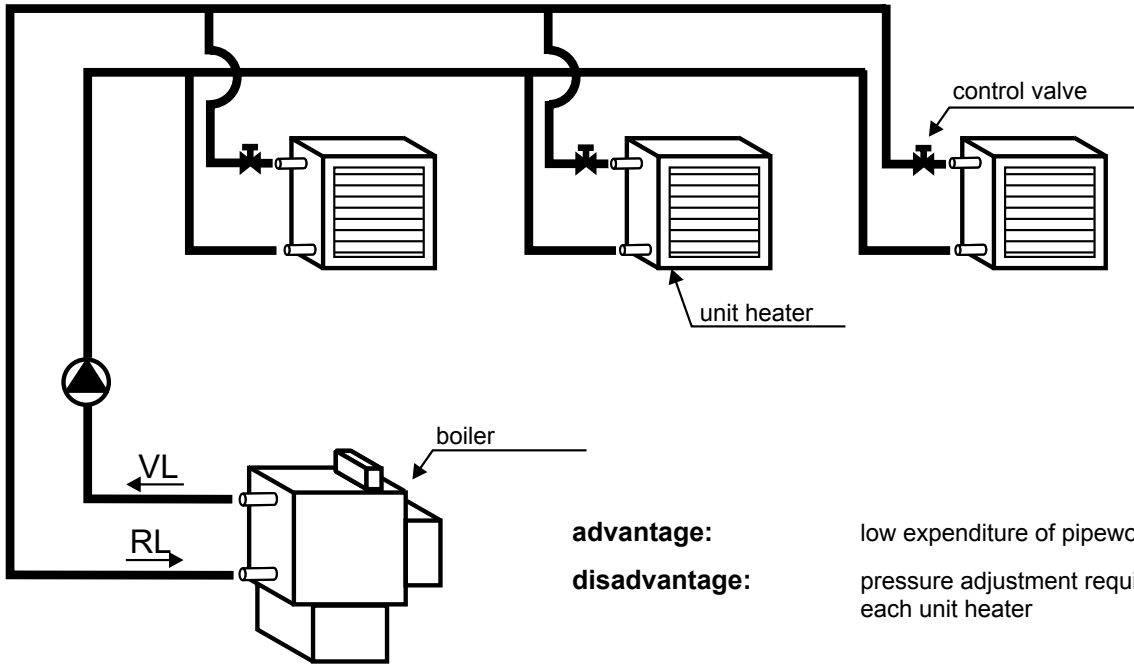

advantage:

low expenditure of pipework

disadvantage:

pressure adjustment required for each unit heater

Example 2:

Pipework assembly according to the Tichelmann system (equally long pipes per unit heater replace the individual adjustment)

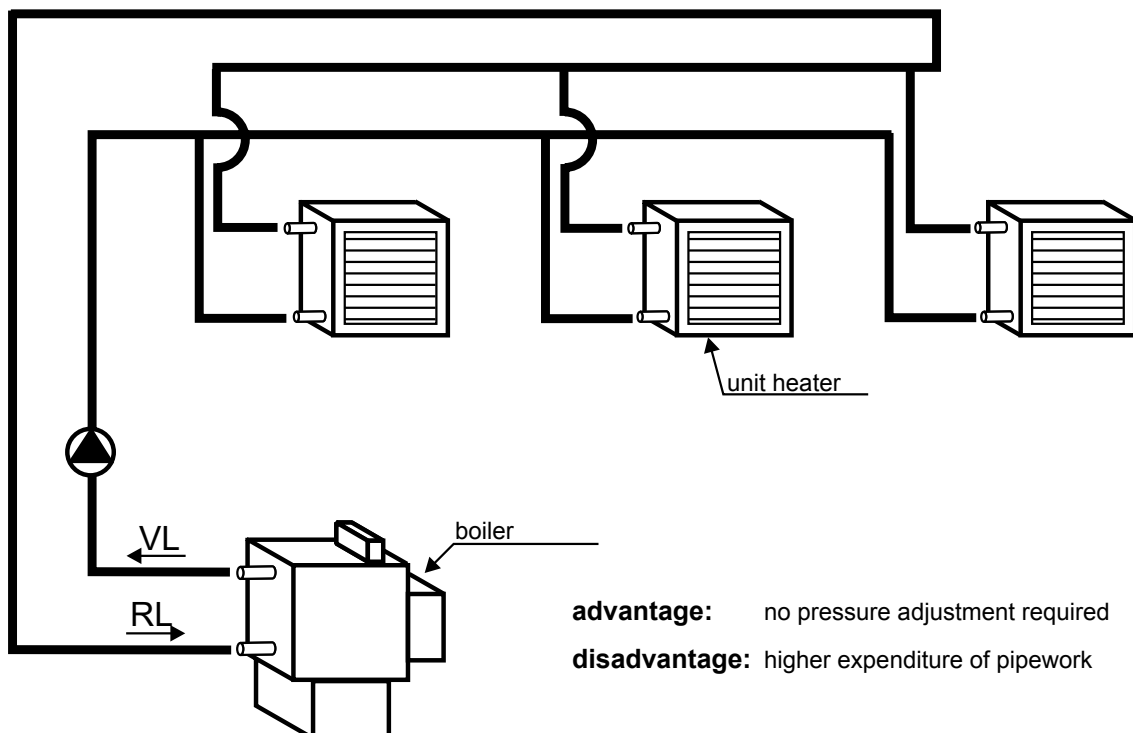

advantage:

no pressure adjustment required

disadvantage:

higher expenditure of pipework

Roof lead-in box and rain protection hood are supplied separately. The rain protection hood is provided with a bird screen as standard. As an option a non-return damper may be supplied for the installation into the rain protection hood, on site.

Roof fastening

As an option and on extra price it is possible to supply 4 fastening angles for fitting the roof lead-in box. Fitting of fastening angles to be done on site because of different types of roofs and variable pitch.

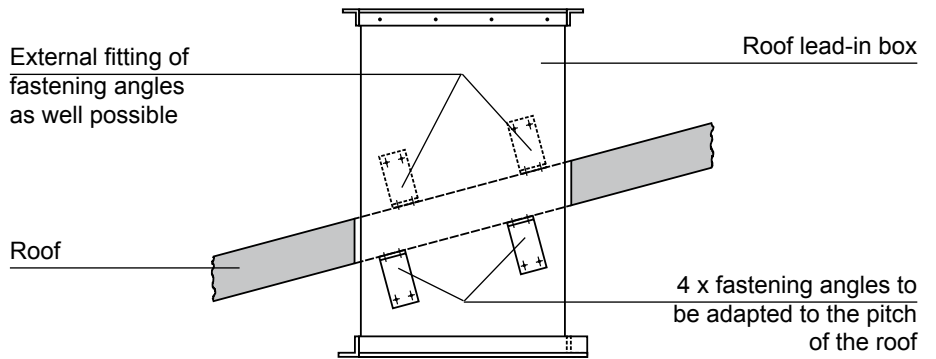

Notice:

The fastening angles are exclusively suitable for fitting the roof lead-in box. They are not designed for carrying the additional weight of unit components installed underneath the roof lead-in box.

Roof sealing

In order to facilitate the sealing of the roof on site, it is possible to supply a covering collar as an optional accessory, not fitted. Installation and fitting in accordance with the drawing:

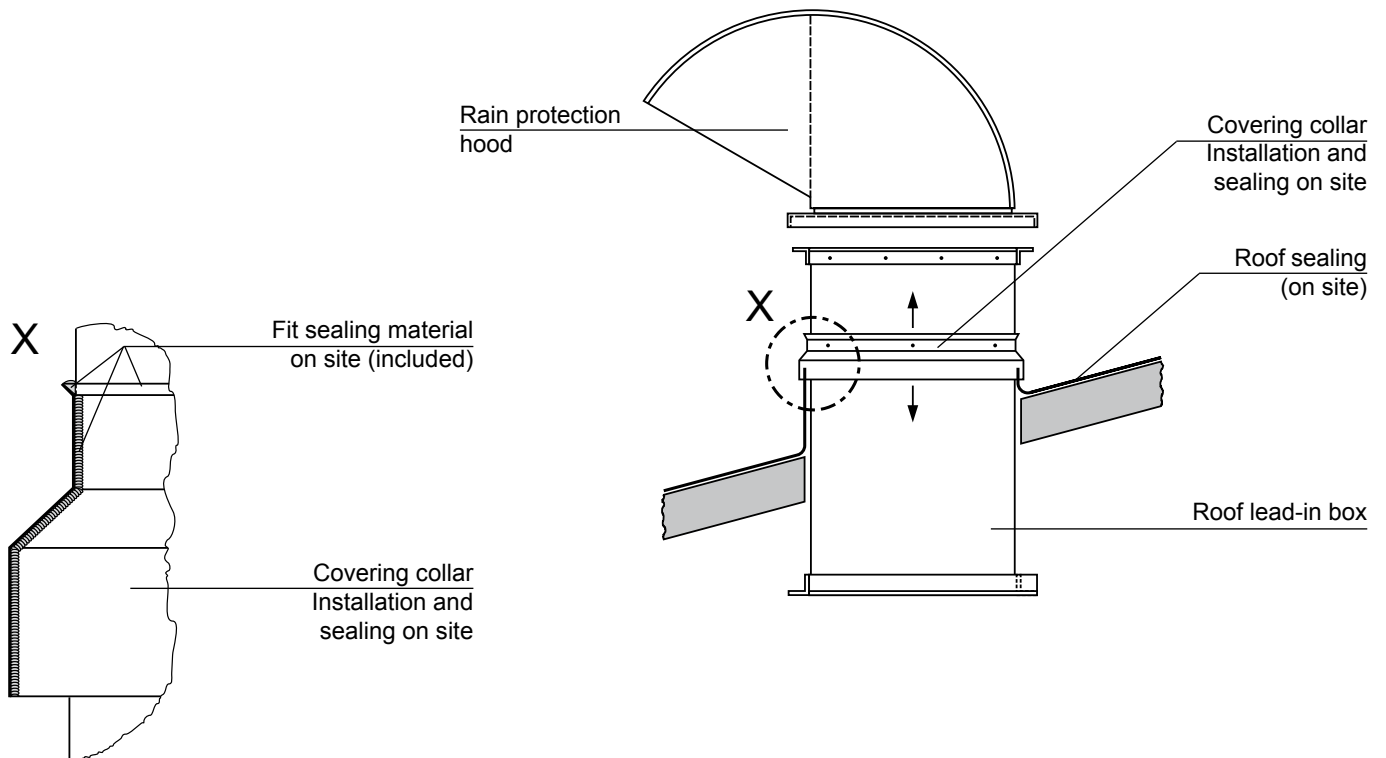

Flexible connection

A unit heater or mixing box are connected to the internal flange of the roof lead-in box (matching bore holes) via a flexible connection "Q". In this case the roof lead-in box has to be on the roof and the mixing box, filter section or unit heater underneath the roof.

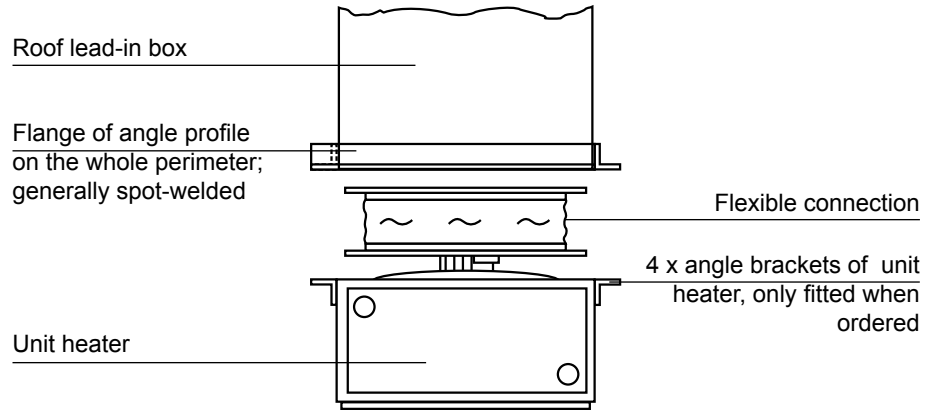

Non-flexible connection

Direct fitting of unit heater or mixing box to the external angle flange. This flange is provided with the matching bore holes for the angle brackets of the unit heater, mixing box or filter section on the whole perimeter.

